

MARKFORGED CASE STUDY

STANLEY INFRASTRUCTURE

Stanley Black & Decker, an S&P 500 company, is a diversified global provider of hand tools, power tools and related accessories, electronic security solutions, healthcare solutions, engineered fastening systems, and more. Stanley Infrastructure, a division of Stanley Black & Decker, is searching for a way to manufacture low volume, complex parts in a cost efficient manner. By leveraging Markforged's Metal X additive manufacturing technology, the Infrastructure team expects to slash capital costs on two different parts — an actuator housing for the PD45 Hydraulic Post Driver and a wheel shaft for the PG10 Profile "Frog" Grinder. Engineers at Stanley Infrastructure rigorously tested the performance, durability, and life cycle of each of the two parts and approved them for use as production parts for a fraction of the cost.

PART COMPARISON

About the Part

The STANLEY PD 45 is a high efficiency hydraulic post hole driver. To actuate the hydraulic driving mechanism, the device uses a group of ball bearings to transfer the trigger pull force into the hydraulic actuator. The actuator housing holds these bearings in series to transfer pull force around a bend. Each housing is tested every time the operator pulls the trigger.

DESIGN COURTESY OF
STANLEY INFRASTRUCTURE

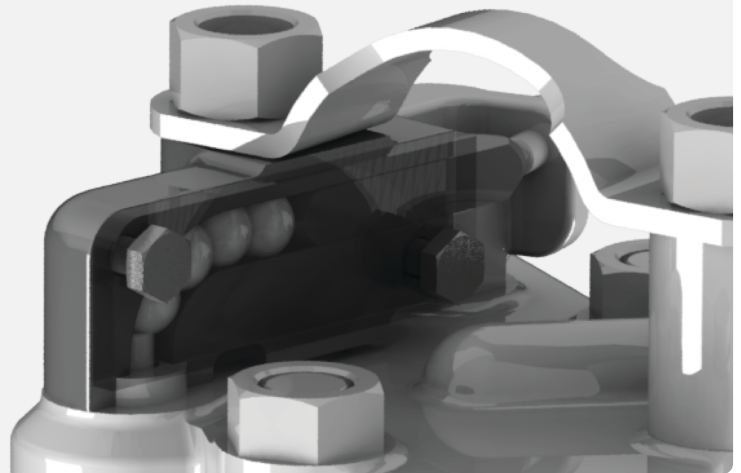

Design Alterations

Original Part

The original actuator housing consisted of four parts - a cast and machined main housing, laser cut cover plate, and two bolts to fasten the housing assembly together.

Markforged Part

Stanley Infrastructure engineers redesigned the part to print on the Metal X. Instead of a four part assembly, the redesigned part prints in one piece without supports.

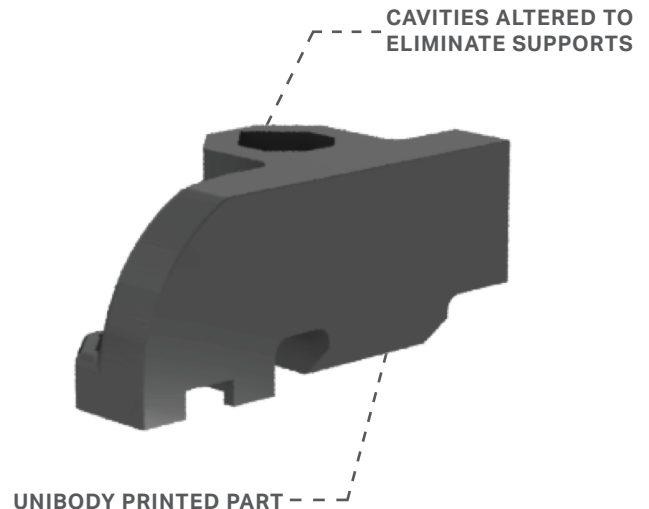
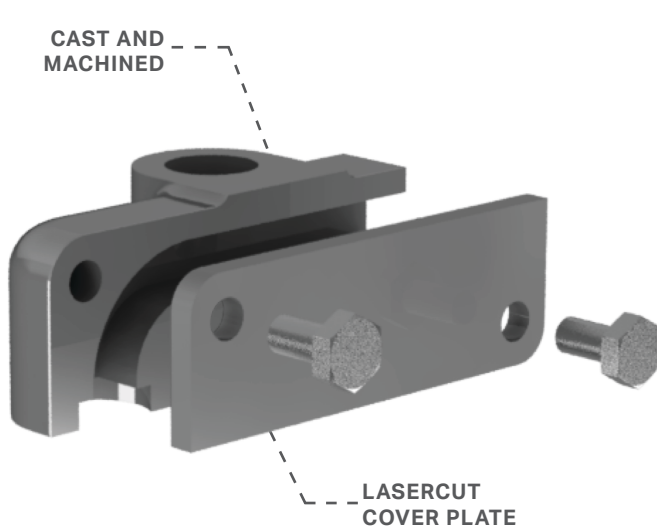

PERFORMANCE COMPARISON

Physical Performance

Stanley Infrastructure tested three identical parts printed on the Metal X. These parts proved durable through tens of thousands of cycles and strong enough to handle significant compressive load while also being 53% lighter.



LIFE CYCLING	STRENGTH	WEIGHT SAVINGS
Pass	Pass	53%

Cost Performance

By replacing their current manufacturing work flow with the Metal X, Stanley Infrastructure saves between 34% and 48% on manufacturing costs and slashes part lead time by 69%. While these are significant savings, they even better leverage the Metal X on single part manufacturing (in this case, Stanley Infrastructure often produces single replacement parts for devices in the field). Because their existing process only produces parts in batches, printing single parts with the Metal X is **12.5x cheaper** and **20x faster** than casting and machining. The Metal X further undercuts this process by being a pay-per-part machine instead of a pay-per-batch machine.

	COST SAVINGS	TIME SAVINGS
Annual Volume	34% - 48%	69%
Single Component	92%	95%

Analysis

According to a Stanley Infrastructure engineer, **“it is very feasible to leverage the Metal X platform in additively manufacturing the discussed actuator housing with very minimal capital and time investment.”** They believe that they can save thousands of dollars per year on this part alone, while replicating the part quality and reliability that they expect from machined parts.

PART COMPARISON

About the Part

The STANLEY PG10 Profile Grinder is used to perform surface finishing operations on railroad tracks. The wheel shaft holds adjustable guide wheels onto the body of the grinder. Each part is loaded with the full weight of the grinder and subject to shock loads. The geometry of this part, with its large flange and long aspect ratio, means that it's volumetrically inefficient and expensive to manufacture.

DESIGN COURTESY OF
STANLEY INFRASTRUCTURE

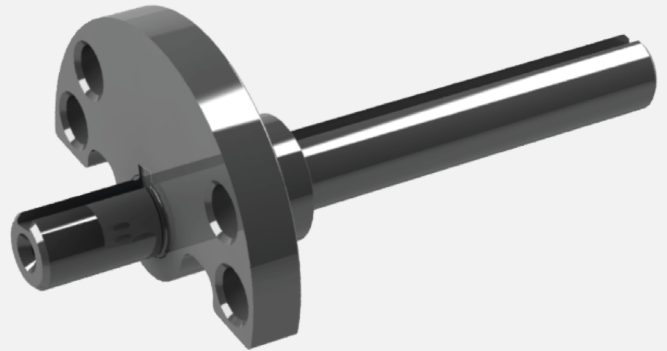

Design Alterations

Original Part

Stanley Infrastructure used to machine these parts out of a single block of steel. Because of the size of the flange and the length of the shaft, they wasted ~90% of the stock material in each part.

Markforged Part

With the help of Markforged, Stanley Infrastructure engineers redesigned the wheel shaft to be a three part assembly. By purchasing an off-the-shelf shaft and key, they were able to easily print the flange on the Metal X.

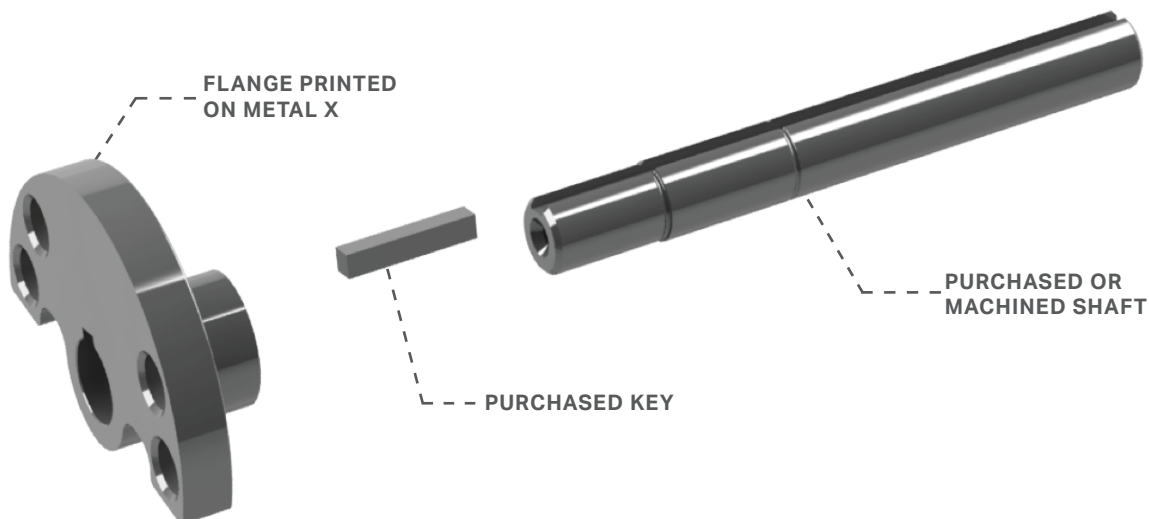

PERFORMANCE COMPARISON

Physical Performance

Stanley Infrastructure tested three samples with drop tests. The parts passed durability testing (many small drops of the grinder onto a steel work surface) and abuse testing (extreme shock testing involving drops of the same grinder from high heights, such as a truck bed) while being 20% lighter than the original part.

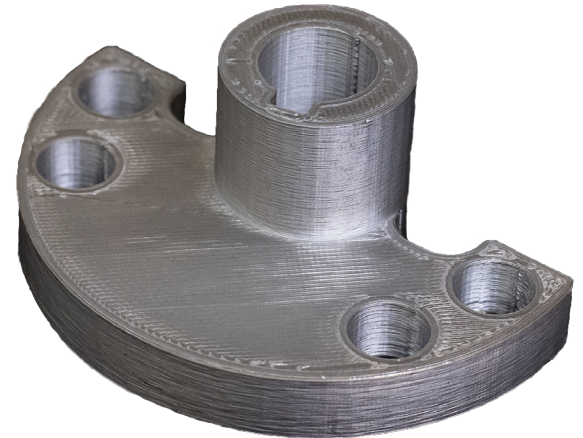

DURABILITY	ABUSE	WEIGHT SAVINGS
Pass	Pass	20%

Cost Performance

By replacing the wheel shaft with Markforged’s printed flange and shaft assembly, Stanley Infrastructure cuts their production lead time in half and saves between a quarter and half of their production budget for full volume manufacturing. However, since this part is a high wear component and the production volume for this grinder is low, the most lucrative use of the Metal X comes from the astronomical savings they get in one-off manufacturing. Replacing the inefficient-to-machine original part with a Metal X print yields **25x cost savings** and **50x time savings** on a single part manufacturing basis.

	COST SAVINGS	TIME SAVINGS
Annual Volume	25% - 45%	48%
Single Component	96%	98%

Analysis

Parts printed on the Metal X have the potential to save industrial customers significant capital if utilized correctly. By designing intelligently for these machines, minimizing print time, and using off the shelf parts when possible, it’s possible to produce high quality parts much more cost effectively than subtractive manufacturing.