

SUPERIOR PRODUCT DESIGN THROUGH POWERFUL IN-CAD SIMULATION

White Paper

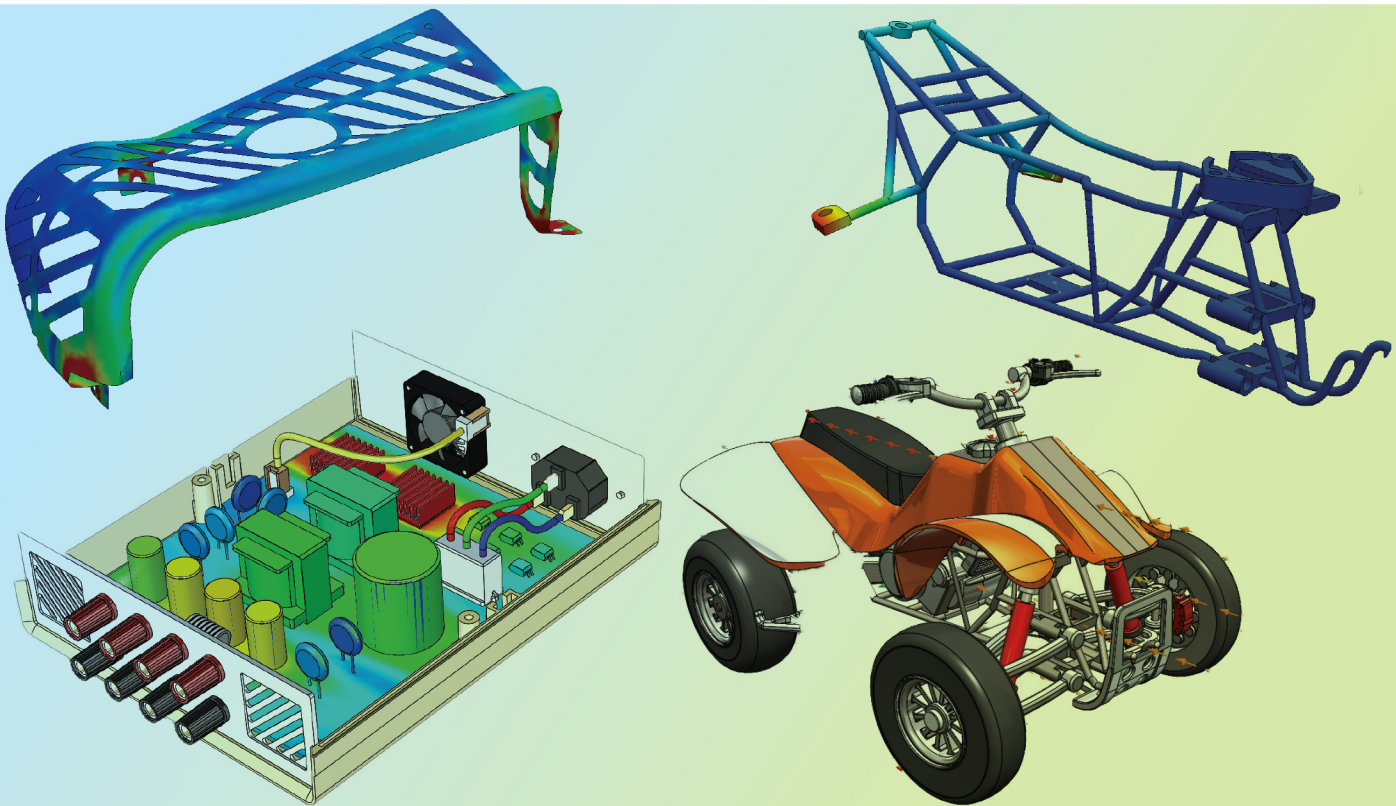

OVERVIEW

Engineering successful, innovative products in today's competitive environment requires simulation power. The ability to analyze the multifaceted physical performance characteristics of a design before making a prototype can substantially increase productivity. Companies need robust simulation tools to efficiently overcome time, budget, and quality demands. SOLIDWORKS® Simulation delivers powerful simulation capabilities that can solve complex analysis problems through structural, thermal, frequency, dynamics, and flow simulations, helping you design better, more innovative products faster and more cost-effectively.

SIMULATING COMPLEX PHYSICS DRIVES INNOVATION

Innovative. Reliable. Efficient. These are not only the characteristics of successful product designs but also of the design and engineering organizations that create them. To develop products with these attributes, you need to gain as much information as you can about how your design will perform under real-world conditions, and be able to obtain these insights as quickly as possible. Manufacturers no longer have the luxury of performing lengthy physical tests to understand how a design will behave. Bringing innovative, reliable products to market quickly requires simulation technology.

And not just any simulation package will do. In many cases, you will need to simulate complex physical behaviors requiring powerful nonlinear, dynamics, fluid flow, and coupled simulation capabilities, like those available in SOLIDWORKS Simulation. By simulating the complex physics impacting your designs, you will gather critical information that will help you make important design decisions. Using SOLIDWORKS Simulation software to more easily conduct sophisticated analyses, you can obtain this information faster than ever, and you don't have to hold a Ph.D. to do it.

Many of the world's successful manufacturers use SOLIDWORKS Simulation because it allows their engineers to simulate complex physics in an easy, straightforward manner. With its pioneering work in user interface design, powerful solver technology, and advanced results visualization tools, SOLIDWORKS has created an advanced simulation platform that can solve challenging analysis problems. By taking advantage of multicore, multiprocessor computers, SOLIDWORKS Simulation can solve your engineering problems in an efficient and cost-effective manner.

SOLIDWORKS Simulation provides accurate, efficient solutions to your difficult analysis problems, accelerating time-to-market, optimizing material usage, minimizing design uncertainty, eliminating errors, preventing returns and warranty claims, and increasing profitability. Most importantly, simulating complex physics can help you drive innovation by revealing important insights about your designs that you could not practically learn any other way.

With SOLIDWORKS Simulation technology, you will encourage collaboration across your engineering team, advance the professional development of team members, and drive design innovation. You will also foster a design and engineering organization that is innovative, reliable, and efficient—a rewarding work environment that will attract, retain, and challenge skilled engineering professionals.

THE WORLD IS NONLINEAR AND DYNAMIC

To accurately simulate the structural behavior of your designs, you need powerful and reliable analysis capabilities, such as those available in SOLIDWORKS Simulation. The physical world where you create and engineer products is not a flat, linear domain where structural responses are always proportional to the applied loads. The real world is 3D, nonlinear, and dynamic.

Simulation technology allows you to use computer-based, mathematical modeling to approximate and simulate the complex phenomena of the physical universe. To produce approximations that are as close to reality as possible, you need the power of SOLIDWORKS Simulation nonlinear and dynamics analysis capabilities. While a rough view of a design's performance, using linear analysis tools, may be helpful for basic concepts, product designs are increasingly sophisticated and present a growing number of more complex analysis problems, requiring nonlinear analysis for an accurate prediction of performance.

SOLVING NONLINEAR SIMULATION PROBLEMS

Nonlinear structural analysis problems generally fall within three categories: nonlinear materials, nonlinear geometries, and nonlinear interactions between parts. Of course, you may face a simulation challenge that involves all three. You may be using a hyperelastic material, such as an elastomer, in a shape that constitutes both structural nonlinearities, where the response varies disproportionately to the applied forces, and geometric nonlinearities, where displacements alter a structure's stiffness.

The practical applications of nonlinear materials analysis vary widely. In a nonlinear analysis of a component, "failure" may be defined by the extent that a material yields, rather than whether the material yields, as in linear analysis. You may also want to examine different failure modes, such as buckling, snap-through, "oil-canning effects," or large displacements. Many modern materials, such as plastics, synthetics, and composites, have unique properties that require nonlinear materials analysis to capture their complex load response behavior. An increasing number of products, such as medical stents or plastic clips, are designed to deform in shape and stretch without failing. Such behavior can be understood only through a combination of nonlinear material and nonlinear geometry analyses.

When you're dealing with nonlinear materials in a flexible structure, you'll need to combine large displacement and nonlinear material analyses. An important consideration for these simulations is that as the part changes shape, it can experience a phenomenon known as "stress stiffening." Stress stiffening can either increase or decrease the component's stiffness, depending upon the applied loads and the component geometry. At times—as is the case with membrane effects—a relatively small change in shape results in a substantial change in stiffness.

WORKING WITH NONLINEAR LOADS AND BOUNDARY CONDITIONS

While the term "nonlinear" primarily refers to the nature of a design's physical response, the loads and boundary conditions that elicit nonlinear responses can also be nonlinear, or dynamic, in nature. When the applied load is a function of time, and the material response is a function of displacement or temperature, designs can respond in ways that are difficult to predict yet easily simulated with SOLIDWORKS Simulation.

Predicting the impact of time-varying loads and other load-related effects, such as damping and inertia, which can occur with alternating forces, sudden applied forces, or intermittent loads, requires dynamic analysis capabilities.

The effect of temperature changes brings transient thermal analysis into the mix. The study of "heat up and cool down" load cycles requires transient thermal analysis. Many materials have temperature-dependent material properties, and temperature cycles can have a dramatic impact on the design's structural response to service loads.

SOLVING DYNAMIC SIMULATION PROBLEMS

Structures do more than just deform, buckle, yield, and fatigue under applied loads. They also vibrate in ways that can be fairly obvious or distinctly unpredictable. Vibration can be magnified as a result of load-inertia coupling or amplified by periodic forces as a result of resonance. The advanced dynamics simulation capabilities in SOLIDWORKS Simulation enable you to solve perplexing problems related to vibration, whether it's through modal, modal time history (time response), harmonic (frequency response), random vibration, or drop-test analysis.

Anyone who designs mechanisms or machines with moving parts knows how important it can be to determine the natural frequencies, and the modes of vibration associated with those frequencies, for a given part or assembly. This type of dynamic information is critical for controlling vibration and producing a design that runs smoothly. But it's equally important to study the forced vibration characteristics of your designs where a time-varying load excites a response in one or more components.

...a case in point

NONLINEAR AND DYNAMICS SIMULATIONS STREAMLINE RADAR DEVELOPMENT

A worldwide leader in radar technology development, Reutech Radar Systems uses SOLIDWORKS Simulation to solve nonlinear structural problems as well as dynamic analyses. The company's radar structures are mounted on land, on aircraft, and on ships. They sustain a wide variety of loads, including wind, temperature, deflection, seismic vibration, weight, and motion.

"We have to ensure that our products can function in both the extreme cold and the desert heat, from -40 C to 55 C, and can withstand the structural loads of severe storms and seismic conditions," Chief Mechanical Engineer Carel Kriek explains. "To do that cost-effectively and expeditiously, we must be able to predict physical behavior before building a single component.

"We are making a more accurate, higher-quality product by using simulation to optimize the design, instead of building prototype after prototype," Kriek stresses. "Simulation has allowed us to cut the weight of certain components in half because we can simulate how geometry changes can produce a 25-kilogram component with the same strength and stiffness as a 60-kilogram part.

"Nonlinear dynamic analysis helps us predict the behavior of assemblies containing nonlinear materials," Kriek adds. "We can even forecast radar accuracy due to wind-induced deflection, uneven solar heating on the radar structure, and ship motion. The ability to do all of these different types of analyses is a truly encompassing advantage."

Read the full story here: [Reutech Radar Systems](#)

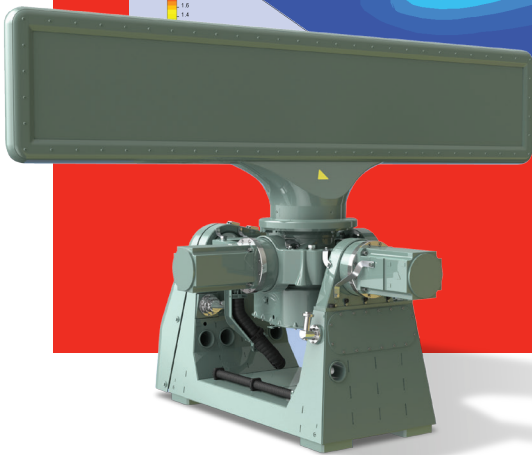
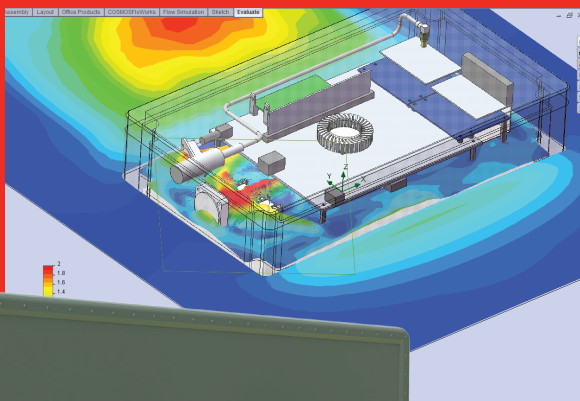
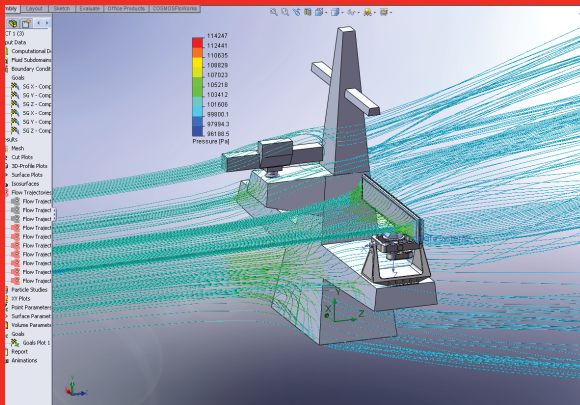

Sometimes a dynamics problem will involve a load that is a function of frequency rather than time, such as a shaker table. This is known as harmonic analysis. It can be beneficial in many types of design, especially those with rotating components. For cases where the load is not deterministic, you can conduct a random vibration analysis, which takes a probabilistic approach to load definition. You can even simulate vibration effects related to the loads generated by an earthquake.

SOLIDWORKS Simulation provides an easy-to-use drop-test analysis tool, so that all designers can understand the stresses generated due to dropping their designs from a specified height onto a flat surface.

By using SOLIDWORKS Simulation to conduct modal, modal time history, harmonic, random vibration, and drop-test analyses, you can better understand the dynamics of your design and use that information to resolve the vibration-related problems that are so common in machine design and in designs that are subjected to vibration loads during shipping or transport.

BENEFITING FROM COMPUTATIONAL FLUID DYNAMICS ANALYSIS

Although structural simulation represents the lion's share of analysis requirements, there is a continually growing need to understand how the behavior and dynamics of fluids—either liquids or gases—affect design performance. While the early applications of computational fluid dynamics (CFD) software primarily focused on the aerodynamics of vehicles, such as aircraft and automobiles, as an alternative to wind-tunnel testing, the technology is now increasingly used to evaluate other flow-related issues, such as cooling, heating, ventilation, and flow-based manufacturing and piping processes.

With SOLIDWORKS Flow Simulation, you can simulate the physical traits of the flow of just about any fluid—including Newtonian and non-Newtonian fluids—allowing you to calculate velocities, pressures, flow rates, and temperatures for liquids and gases that influence your design or process. Some fluids have material properties that are characterized by constant viscosity, and are known as Newtonian fluids. But many types of fluids—such as polymers, blood, ketchup, paint, shampoo and molten plastic—exhibit a nonlinear, or time-dependent, relationship and cannot be described with a single viscosity constant. These fluids are called non-Newtonian fluids.

SOLIDWORKS Flow Simulation analyzes the flow of both fluids and gases, including gases that travel at high speeds and fluids that flow at high pressures. By understanding how design modifications impact fluid flow, and how changes in flow affect design behavior, you can optimize flow and avoid potential performance issues.

IMPROVING FLUID EFFICIENCY

When most of us think of fluid efficiency, or aerodynamics, we typically envision the sleek shapes of racecars, airplanes, and speedboats. Indeed, reducing the effects of drag on a moving vehicle to increase speed—or in the case of an airplane, to strategically position drag to create lift—are common applications for conducting fluid flow analysis. In fact, SOLIDWORKS Flow Simulation allows you to simulate anything that you might learn with expensive wind-tunnel testing.

Yet, fluid mechanics involves much more than the aerodynamic interaction of an object's movement through a fluid. It also comes into play when you consider the internal flow of air through an object, such as airflow through an air conditioning pipe. So whether you are concerned with creating a shape that can travel through the air or defining a geometry that improves internal fluid flows, you can use SOLIDWORKS Flow Simulation to make your design more efficient.

With SOLIDWORKS Flow Simulation, you can evaluate whether you are dealing with a laminar or turbulent flow, and pinpoint where vortices occur. Then you can modify your design to eliminate flow phenomena like these, which can cause flow inefficiencies. You can visualize the characteristics of complex flows using flow trajectories, section plots, and surface plot tools.

IMPROVING THERMAL MANAGEMENT

One of the growing applications for fluid flow simulation is evaluating how flow influences the temperature of the components of a design. As many heating and cooling systems rely on fluids to transfer or dissipate heat, a flow simulation tool can help you evaluate and assess the performance of these systems. SOLIDWORKS Flow Simulation can predict heat transfer in liquids (e.g., boilers and radiators) and gases, such as in forced-air heating and cooling systems. You can also simulate the effects of solar radiation on the temperature of your design.

Using SOLIDWORKS Flow Simulation, you can identify the optimal inlet and outlet conditions to satisfy specific design goals, including force, pressure drop, velocity, and temperature. You can observe how a fluid moves through a system, including the impact of fans, impellers, and ducts on the flow characteristics, and even simulate situations involving multiple fluids.

The rapid growth in the development of products and appliances that leverage electronics creates an ideal scenario for using fluid flow simulation to study the effectiveness of cooling systems. With SOLIDWORKS Flow Simulation, you can evaluate how forced-air flow (fans) affects heat-producing electronic components. With this powerful tool you can apply real-world heat loads and include heat sink emulators to quickly examine how you can modify the flow or the design to cool electronics more effectively.

Instead of spending the time and expense required to prototype and test heating and cooling systems, you can use SOLIDWORKS Flow Simulation to learn exactly how your system will function, and how design modifications can improve performance. Using this approach, you'll be able to avoid field failures and operational issues, while controlling development costs at the same time.

UNDERSTANDING FLOW-BASED PROCESS AND MANUFACTURING

In addition to influencing the performance of traditional products, fluid flow can affect the development of systems designed to transport fluids—some of which may be hazardous—under pressure, as well as manufacturing processes that involve materials in a molten or liquefied state. With SOLIDWORKS Flow Simulation, you can gain a thorough understanding of how your flow-based systems and manufacturing processes operate, enabling you to modify designs to optimize performance.

For example, any time that a liquid or a gas is transported and pumped under pressure, there are a variety of components and assemblies that are impacted by flow, ranging from pumps, valves, and regulators to piping runs. With some of these systems, temperature may be an important variable. For others, especially those that carry caustic or dangerous substances, maintaining the integrity of the system and preventing leaks and discharges is the overarching requirement. No matter what type of fluid is involved or how it is processed, SOLIDWORKS Flow Simulation can help you study the physical characteristics of the system as well as how each part performs. You can also account for sophisticated effects like porosity, cavitation, and humidity, and track the behavior of particles suspended within a flow. With this information, you can address potential problem areas and refine components that have been over-designed.

Similarly, when your manufacturing process involves handling a fluid material, you can study how flow affects performance. You can observe how manufacturing equipment design changes enable you to modulate temperature, pressure, velocity, and volume. With SOLIDWORKS Flow Simulation, you have a virtual fluid dynamics testing laboratory at your fingertips, enabling you to simulate and improve flow performance in an efficient, cost-effective manner.

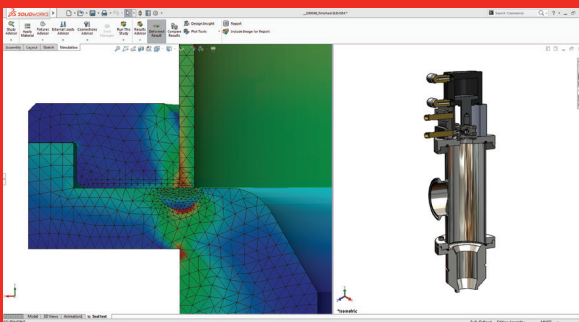
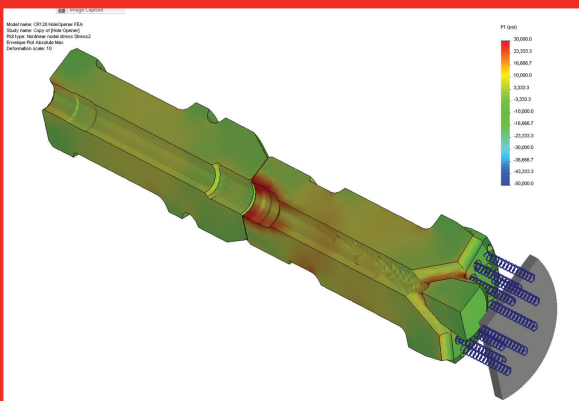
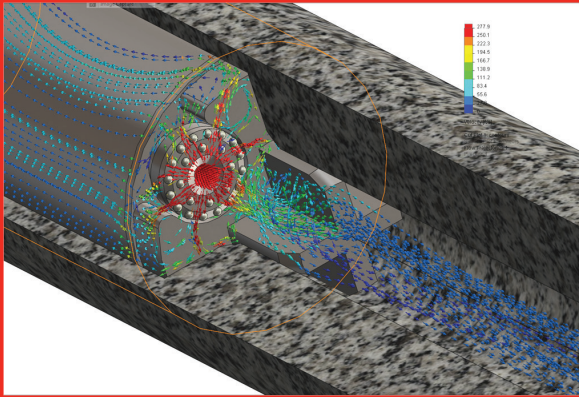

...a case in point

FLUID FLOW AND RAPID RESULTS CONTRIBUTE TO CHILEAN MINER RESCUE

As the world watched the miraculous rescue of 33 Chilean miners—trapped 2,000 feet underground for two months— few knew that a redesigned drill from Center Rock, Inc. made the rescue possible. Center Rock is a leading manufacturer of drilling supply equipment. The company’s pneumatic bits utilize wear-resistant carbide and diamond tips on a series of rotating hammers. Unlike the bits in conventional rotary drills, Center Rock’s percussive hammer bits can tunnel through even the hardest, most abrasive rock, as was the case at the San José Mine in Chile.

Developing its industry-leading technology demands 3D design and simulation tools, according to Rudy Lyon, Center Rock’s senior engineer and product development manager. “Designing an effective percussion rock bit is challenging,” Lyon explains. “You have to visualize how the hammers will function underground, analyze the structural stresses involved, and even understand the impact of airflow on cuttings removal. We usually perform these simulations concurrent with the design process, but, at critical times, we need to conduct simulations and redesign bits during an actual deployment. That was the scenario during the Chilean mine rescue.”

Using SOLIDWORKS Flow Simulation, Center Rock customized the bit to let drill cuttings fall into the mine. “The SOLIDWORKS Flow Simulation studies enabled us to customize the tool by putting a band around the bit, so that two-thirds or more of the air went down the shaft,” Lyon recalls. “We needed an adequate split of air to let the cuttings fall by gravity, where the trapped miners kept busy clearing about eight dump-truck loads of spoil. SOLIDWORKS Flow Simulation allowed us to reconfigure the tool and reach the miners faster.”

Center Rock’s simulations proved to be accurate when the rescue team pulled the 33 miners to safety on October 9, 2010. Many watched the miraculous event unfold on television. However, only the Center Rock team knew about the important contribution of SOLIDWORKS Flow Simulation in the redesign of the bit that enabled the miners to return to the surface two months ahead of schedule.

Read the full story here: [Center Rock](#)

SIMULATING THE REAL WORLD REQUIRES COUPLED ANALYSIS

While a large portion of simulation problems examine a particular type of physical phenomena, such as nonlinear structural, dynamics, fluid dynamics, and thermal analyses, there are many situations that require a combined sequential physics approach. Examples of sequential physics simulations include thermal stress or thermomechanical (thermal/structural), fluid structural interaction (flow/structural), fluid flow with heat transfer (flow/thermal), and fluid structural interaction with heat transfer (flow/thermal/structural).

The combination of SOLIDWORKS Simulation and SOLIDWORKS Flow Simulation provides you with a powerful, integrated suite for analyzing many possible combinations of physical phenomena, so you can gain a definitive understanding of how various physical phenomena affect the way your design will function and perform.

IMPACT OF TEMPERATURE ON STRUCTURES

Most products are not deployed in environments that maintain a single uniform temperature, and many products are subjected to heating and cooling cycles that can affect a structure's mechanical integrity and response. SOLIDWORKS Simulation can help you analyze the impact of heat on structural performance.

For example, in some cases, the distribution of heat within a structure can influence how a design will deform, and conversely, structural deformation can affect the ways that heat moves throughout a structure. Sometimes, the nature of this interaction is primarily in one direction—the structural response alters thermal behavior or thermal responses affect structural performance. At other times, the interaction is both ways—when each type of physical response impacts the other. This is an interactive process that often requires a nonlinear thermal/structural analysis to simulate correctly.

In addition to situations where the interplay of two types of physical phenomena is of interest, there are circumstances where the interaction among physical phenomena is three-fold. You can use the combination of SOLIDWORKS Simulation and SOLIDWORKS Flow Simulation to solve engineering challenges for which a sequential physics analysis that couples thermal, flow, and structural responses is necessary.

For instance, let's say you are designing a system in which fluid flow alters temperature, the changes in heat transfer cause structural deformation, and the deformation changes the boundary governing the flow. This changes the nature of the flow, which affects temperature, and the circle of interrelated physical responses continues. This is a classic thermal/flow/structural coupled simulation problem.

While not all engineering challenges require a three-pronged thermal/flow/structural coupled simulation solution, there are a large number that do. By using SOLIDWORKS Simulation solutions to meet your nonlinear structural, dynamics, fluid flow, and thermal analysis needs, you'll have a powerful tool in your inventory when and if you need a coupled simulation solution.



...a case in point

MODERNIZING EXPLOSION RELIEF VALVES WITH EXPLOSIVE RESULTS

Penn-Troy Manufacturing, Inc. is a leading manufacturer of specialty valves for use in water treatment systems, wastewater treatment plants, and marine diesel engines. The company's Troy Valve Division produces standard and custom valves for the water and wastewater industries. Its Bicara Valve Division supplies crankcase explosion relief valves, which prevent engine room explosions and fires related to crankcase ignitions.

Penn-Troy used SOLIDWORKS Simulation Professional and SOLIDWORKS Flow Simulation software to simulate a range of explosive forces for the redesign of the Bicara valve. The company can simulate the structural and vibration effects of a crankcase explosion, such as identifying where the bolts will give out, locating where the resonance medium will be, and identifying where to add material or ribs. Using SOLIDWORKS Flow Simulation software, Penn-Troy can simulate the response of the porous sintered metal used in the valve to a crankcase explosion. By running simulations, the company has reduced prototyping, saving between \$40,000 and \$50,000; cut valve weight by 10 percent, realizing material savings; and increased valve strength, all while producing a more robust design in half the time.

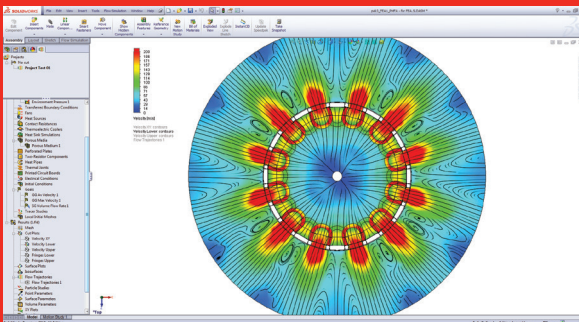
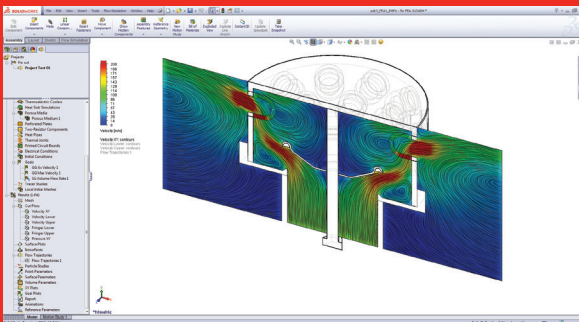

"SOLIDWORKS Simulation tools save us thousands of dollars," Mike Kafka, lead mechanical engineer at Penn-Troy, notes. "I ran fluid flow simulations on six different configurations to determine the valve design that performed best for venting exhaust gases with an even flow distribution. SOLIDWORKS Simulation is also enabling us to quickly develop new sizes of our Troy valve line without a lot of prototyping because we can calculate the stresses and loads associated with different levels of torque and flow pressure."

Read the full story here: [Penn-Troy](#)

MODEL THE WORLD'S COMPLEXITY WITH SOLIDWORKS SIMULATION

The ability to predict how your designs will perform under real-world operating conditions is the essence of engineering and the purpose of prototyping. Yet, in today's competitive global market, manufacturers can no longer afford to take the time or incur the costs of conducting extensive physical testing. Increasingly, the key to engineering successful products is to leverage simulation technology to quickly and cost-effectively obtain valuable design performance information that can help you design better, more innovative products and deliver them to market faster than the competition.

To accurately and effectively simulate the complexity of real-world, physical phenomena, and address their effects on your designs, you need a powerful analysis tool like SOLIDWORKS Simulation. Whether you need to analyze nonlinear mechanics, vibration, heat transfer, fluid dynamics, or coupled systems, the combination of SOLIDWORKS Simulation and SOLIDWORKS Flow Simulation can help you overcome your most difficult engineering challenges. Many leading manufacturers use SOLIDWORKS Simulation solutions because the software allows you to solve complex analysis problems without complexity.

With SOLIDWORKS Simulation technology, you'll be able to get answers to your pressing and challenging engineering questions more efficiently and cost-effectively than through prototyping or by using other analysis tools. Access to critical design performance information will help you shorten time-to-market, cut development costs, reduce material usage, validate design choices, improve quality, prevent returns and warranty claims, and increase profitability. In short, SOLIDWORKS Simulation will help you, and your organization, become more innovative, reliable, and efficient.

Our 3DEXPERIENCE® platform powers our brand applications, serving 12 industries, and provides a rich portfolio of industry solution experiences.

Dassault Systèmes, the 3DEXPERIENCE® Company, provides business and people with virtual universes to imagine sustainable innovations. Its world-leading solutions transform the way products are designed, produced, and supported. Dassault Systèmes' collaborative solutions foster social innovation, expanding possibilities for the virtual world to improve the real world. The group brings value to over 210,000 customers of all sizes in all industries in more than 140 countries. For more information, visit www.3ds.com.



3DEXPERIENCE®