

BOWHEAD CORP. HELPING DISABLED PEOPLE ENJOY THE GREAT OUTDOORS WITH SOLIDWORKS FOR ENTREPRENEURS

Case Study



With the diverse design and engineering capabilities of SOLIDWORKS for Entrepreneurs software, Bowhead Corp. developed and introduced its innovative hybrid ATV/mountain bike a year ahead of schedule, bringing to life the dream of Co-Founder and Inventor Christian Bagg, shown here riding the Reach, of helping people with disabilities enjoy the great outdoors.

Challenge:

Develop an innovative, powered and durable conveyance and mobility aide that enables disabled people to access mountain trails, woodland hikes and the beauty of the great outdoors.

Solution:

Utilize SOLIDWORKS for Entrepreneurs solutions to develop and manufacture the Bowhead Reach powered bike.

Results:

- Cut development cycle by a full year
- Reduced number of prototyping cycles required
- Leveraged 3D printing for development, prototyping and production
- Improved access to outdoors for people with disabilities

Bowhead Corp. Co-founders Christian Bagg, Dean Miller and Will Gill are on a mission to make access to mountain trails, woodland hikes and the beauty of the great outdoors a reality for disabled people around the world. Bagg, who became paralyzed from the waist down due to a snowboarding accident in 1996, has spent the past two decades developing wheelchairs, skis and other conveyances that enable paraplegics, quadriplegics and other disabled people to visit and explore wilderness areas, like the headwaters of the Bow River in the Canadian Rockies, for which the company is named.

Bagg, inventor and designer, and Co-founder Gill, now Bowhead director of research and development, met in the University of Calgary machine shop, where both men had studied. Following Gill's work implementing 3D printing technology at the engineering machine shop at the university and bringing his expertise to the Tom Baker Cancer Center, he was approached by Bagg with an idea for an electric-powered, three-wheeled bike with a two-wheel articulating front end and asked if the prototype design could be 3D printed using carbon fiber.

"Christian came to me with a Markforged 3D printer and asked me, 'Can you run this?' Gill recalls. "That was the beginning of our collaboration that led to the founding of Bowhead Corp. I saw the development of the bike that has become the Bowhead Reach® as a good cause, similar in many ways to the work that I did with the Formula SAE team as a student, and an opportunity to leverage my growing 3D printing expertise."

Because Gill had used SOLIDWORKS® 3D design tools as a student, the new company chose to use SOLIDWORKS for Entrepreneurs design, simulation, communication and visualization tools to complete development of the innovative bike, which looks like a hybrid between a mountain bike and an all-terrain vehicle (ATV). "Personally, I was really into SOLIDWORKS and especially valued the way the software operates with the

Markforged carbon-fiber 3D printers that we use," Gill explains. "The Reach required complicated configurations and complex 3D-printed assemblies, for which SOLIDWORKS provides the perfect solution."

SAVING TIME, DRIVING DOWN COSTS

Using SOLIDWORKS for Entrepreneurs in concert with carbon-fiber 3D printing, Bowhead developed, prototyped and manufactured the Reach in record time and at dramatically lower cost than if it had followed a more traditional design and manufacturing path. "By driving design iterations with SOLIDWORKS and 3D printing, we were able to launch the Reach sooner than anticipated due to reduced prototyping time," Gill stresses.

"By designing parts and assemblies in SOLIDWORKS, 3D printing them, and then trying them out, we were able to iterate very quickly and launch the Reach a year ahead of schedule," Gill adds. "We knew that we had something good, and our enthusiasm coupled with the efficiency of our design tools helped us to advance our design faster and reduce prototyping requirements on the back end."

CREATING COMPLEX, 3D-PRINTED ASSEMBLIES

A SOLIDWORKS capability that is especially helpful to Bowhead is the ability to create complex assemblies using multi-body parts. Instead of 3D printing overly large components or assemblies of several large parts, Gill used SOLIDWORKS multi-body part design tools to create what he calls "Lego®-type" designs, in which large parts or assemblies are broken down into multiple bodies—like Lego bricks. Once printed, these parts click together to form larger parts or an assembly.



"By designing parts and assemblies in SOLIDWORKS, 3D printing them, and then trying them out, we were able to iterate very quickly and launch the Reach a year ahead of schedule. We knew that we had something good, and our enthusiasm coupled with the efficiency of our design tools helped us to advance our design faster and reduce prototyping requirements on the back end."

— Will Gill, Co-founder and Director of Research and Development

"With SOLIDWORKS, I can use 3D sketches to create complicated configurations from the design, which I then use to produce complex 3D-printed assemblies," Gill notes. "These multiple bodies—which because we use carbon fiber are structurally sound, not flimsy—then snap and click together like Legos to form larger parts or assemblies. This approach makes it easier to test and confirm geometry, which helped us complete design iterations a lot faster."

IMPROVING DURABILITY AND PERFORMANCE

Once the Bowhead Reach hit the market—the first bike was delivered to the first customer in November 2018—Gill and Bagg learned that riders were not content with just riding the bike but were actively jumping it over obstacles. "When we first designed the Reach, we didn't think that people would be jumping it eight feet into the air," Gill explains. "After learning more about how our customers use the bike, we took our base design and made modifications to support specialized uses, such as beefing up the shock absorber for jumping or replacing the throttle and braking controls with forearm paddles for use by quadriplegics.

"SOLIDWORKS for Entrepreneurs not only helped us launch the bike early, it also has enabled us to quickly address other functions and requirements," Gill continues. "Whether we're conducting topology and simulation studies to create a lighter, stronger suspension; using SOLIDWORKS Composer™ to automate development of our user manual; or leveraging SOLIDWORKS Visualize to create exciting, compelling imagery, SOLIDWORKS solutions support our mission of helping disabled people enjoy the great outdoors."

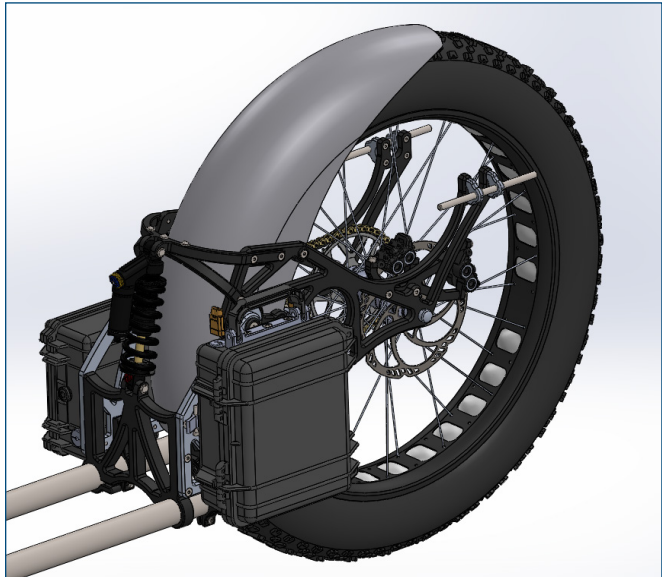
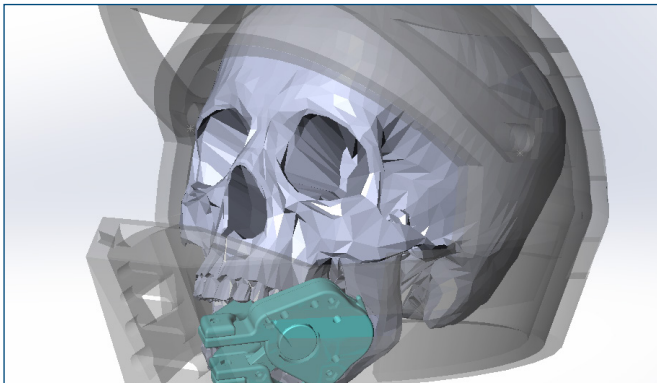

In addition to relying on SOLIDWORKS design tools to accelerate design iterations and 3D-printing-driven prototyping, Bowhead leveraged additional integrated SOLIDWORKS solutions to conduct topology and simulation studies to create a lighter, stronger suspension (top image); automate development of the Reach user manual; and create exciting, compelling rendered imagery of optional components, such as the bite throttle shown in the image on the left.

Focus on Bowhead Corp.
VAR: Hawk Ridge Systems, Calgary, Alberta, Canada

Headquarters: 700 Walbridge Drive
East Lansing, MI 48823
USA
Phone: +1 403 826 8445

For more information
www.bowheadcorp.com

Our 3DEXPERIENCE® platform powers our brand applications, serving 11 industries, and provides a rich portfolio of industry solution experiences.

Dassault Systèmes, the 3DEXPERIENCE® Company, provides business and people with virtual universes to imagine sustainable innovations. Its world-leading solutions transform the way products are designed, produced, and supported. Dassault Systèmes' collaborative solutions foster social innovation, expanding possibilities for the virtual world to improve the real world. The group brings value to over 250,000 customers of all sizes in all industries in more than 140 countries. For more information, visit www.3ds.com.



3DEXPERIENCE®